

CABINA TIPO 1 . Contrapeso Lateral

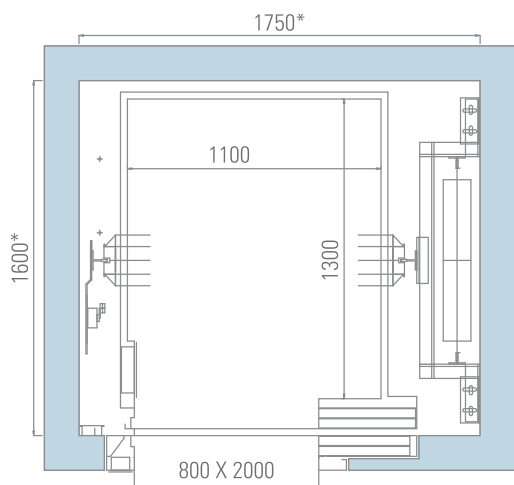

CABINA TIPO 1 . Contrapeso Atrás

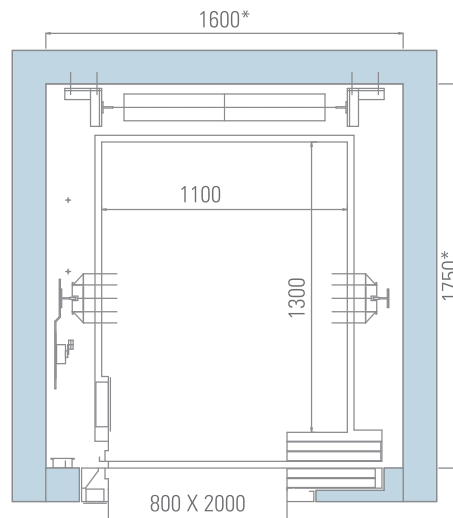

CABINA TIPO 1 . Doble Acceso 180°

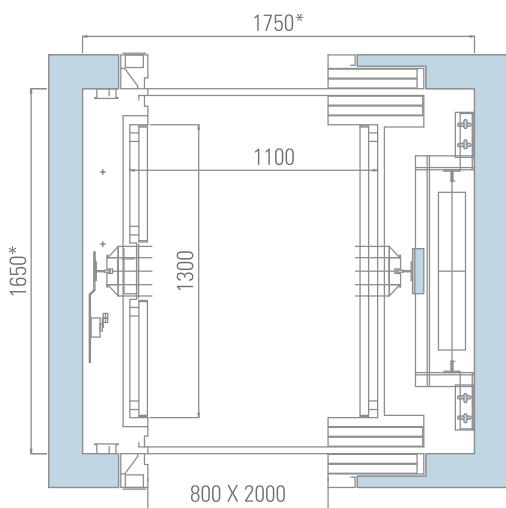

CABINA TIPO 2 . Doble Accesos 90°

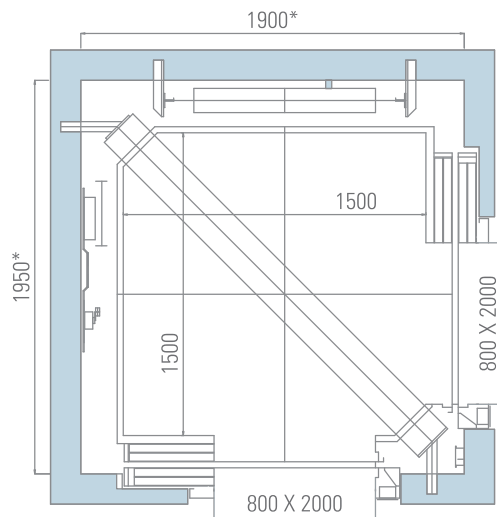

CABINA TIPO 3 . Puerta de 1000 mm

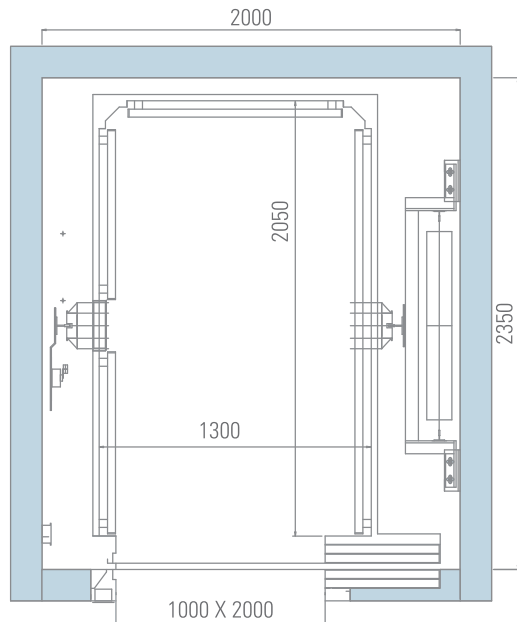

CABINA TIPO 3 . Puerta de 1800 mm

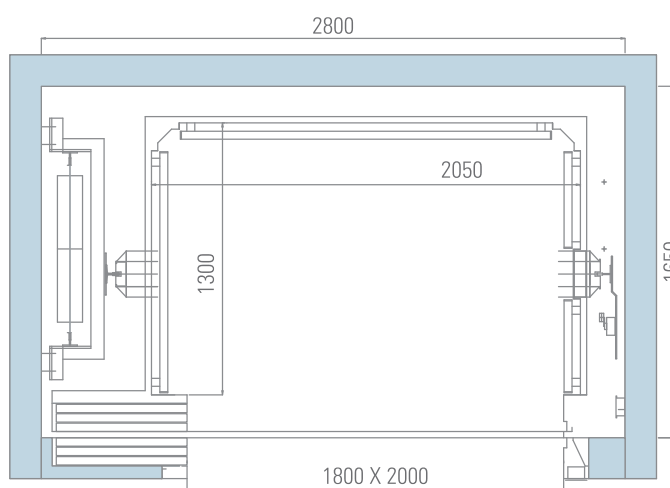

* Pasadizo mínimo aplomado.

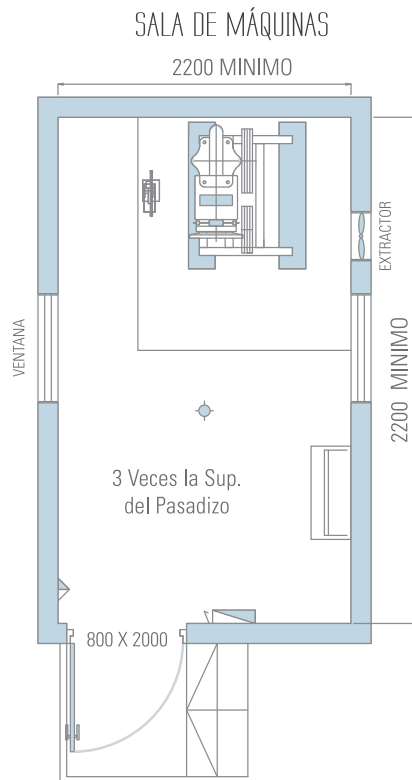

CORTE MÁQUINA ARRIBA



Tabla General de Cantidad de Pasajeros

Nº de Personas	Carga Util (Kg.)	Sup. de Cabina (m2)
4	300	1,00
5	375	1,20
6	450	1,40
7	525	1,60
8	600	1,80
9	675	2,00
10	750	2,20
11	825	2,40
12	900	2,60
13	975	2,80
14	1050	3,00
15	1125	3,20

Sobre y bajo recorrido de acuerdo a la velocidad

Velocidad del coche	Bajo recorrido (mm)	Sobre recorrido (mm)
60 m/m	1350	3800
75 m/m	1450	4100
90 m/m	1500	4200
105 m/m	1500	4200
120 m/m	1500	4200
150 m/m	1500	4200
180 m/m	A consultar	A consultar
240 m/m	A consultar	A consultar
300 m/m	A consultar	A consultar

Ascensores HIDRÁULICOS

PISTÓN LATERAL 2:1

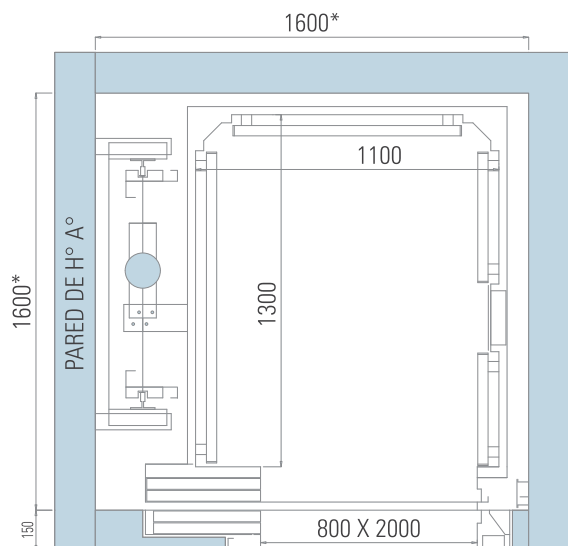

PISTÓN CENTRAL

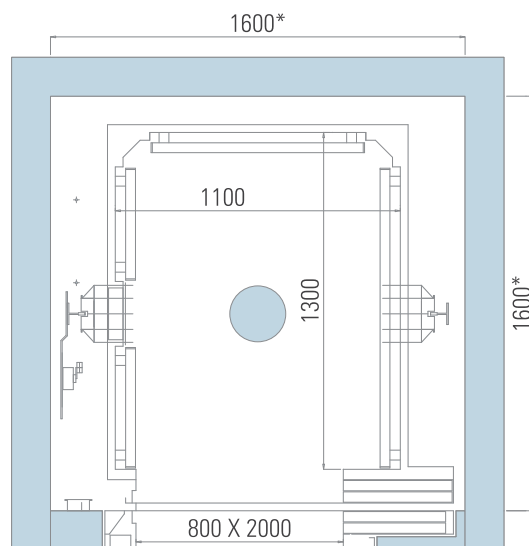

* Pasadizo mínimo aplomado.

SALA DE MÁQUINAS

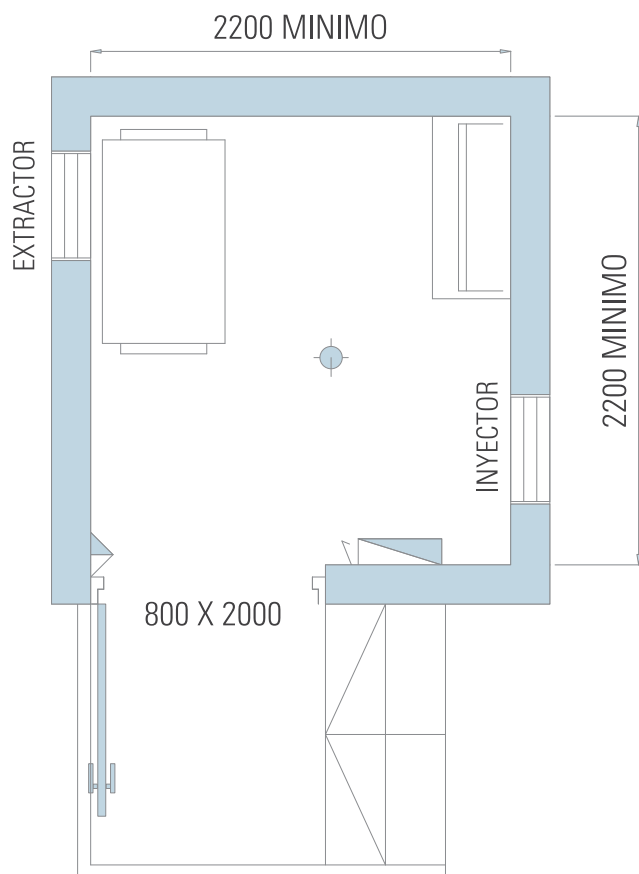

CORTE HIDRÁULICO

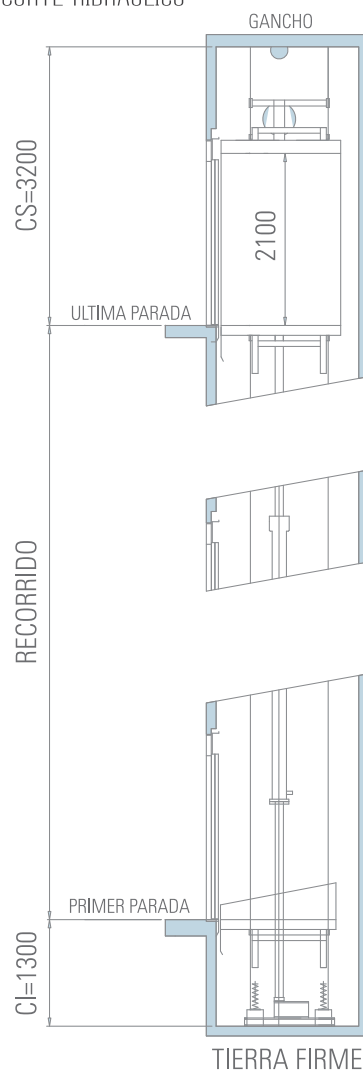

Montavehículos HIDRÁULICO PISTÓN CENTRAL

PLANTA

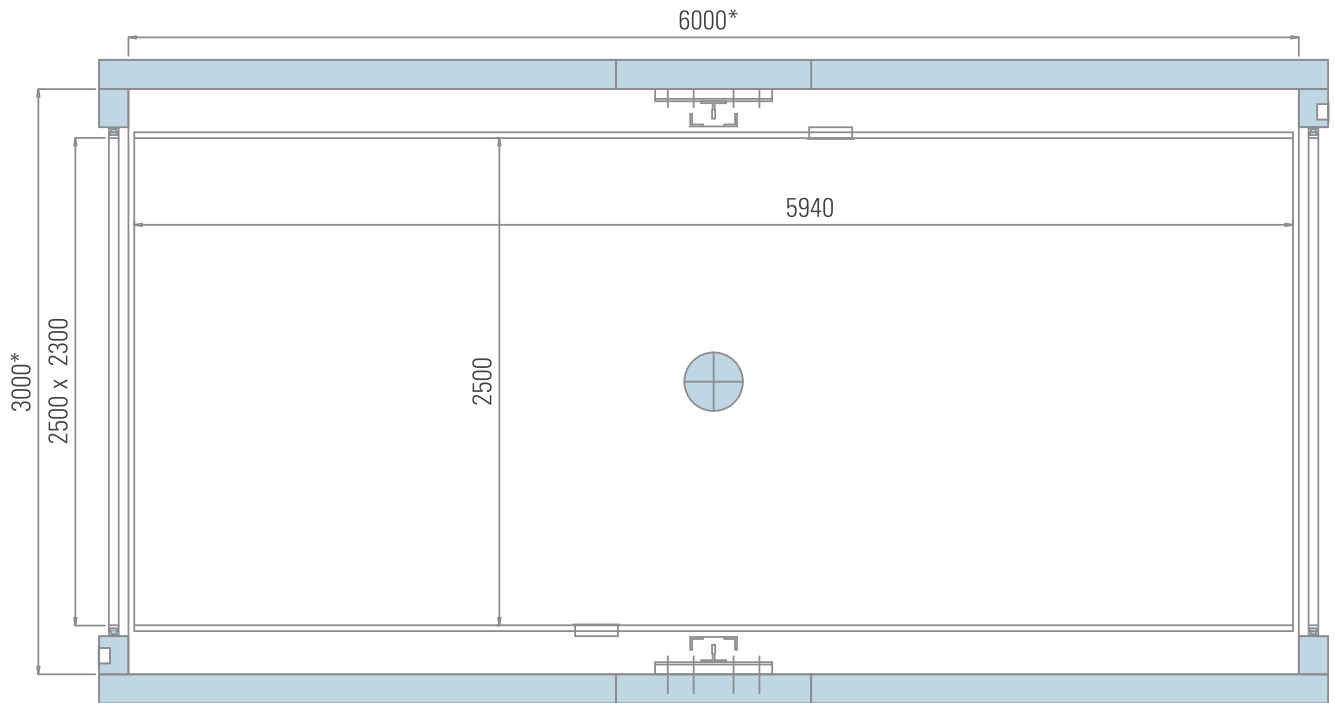

CORTE

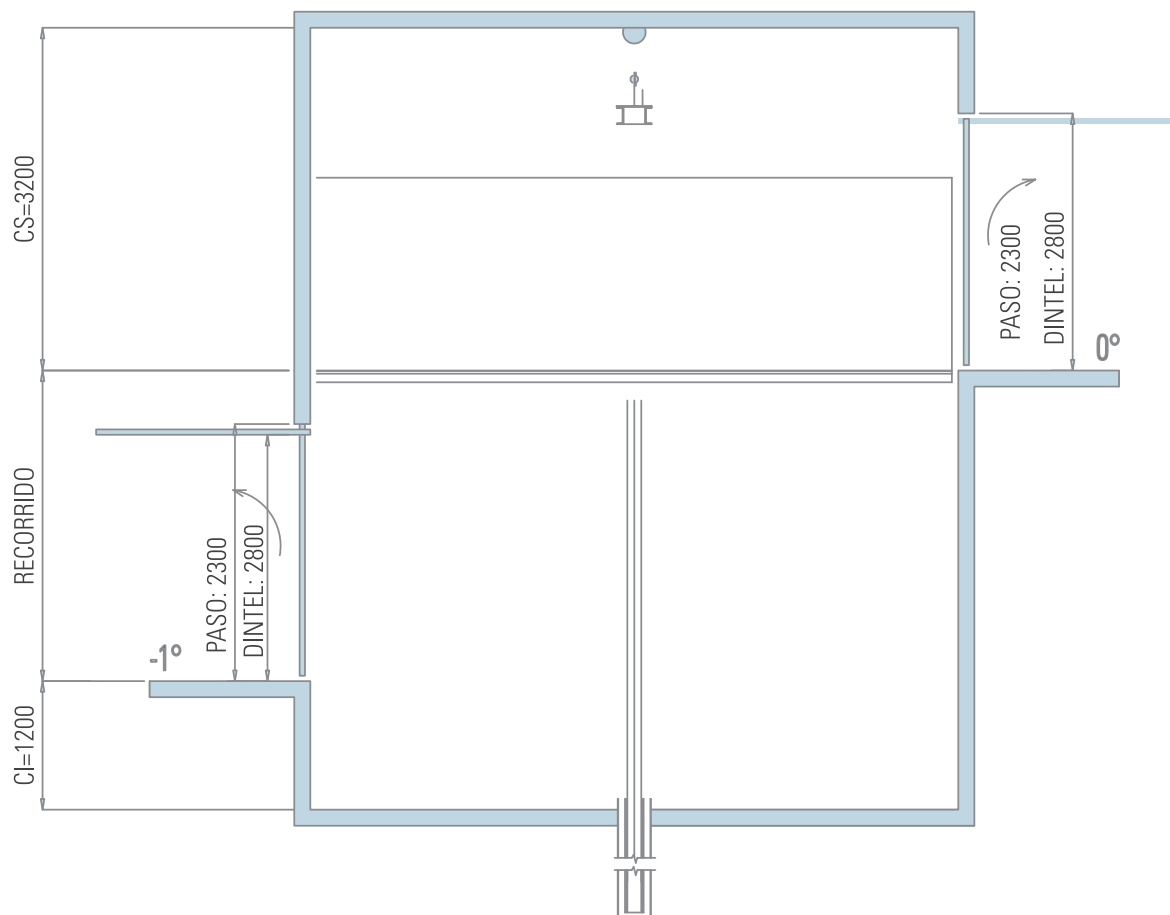

Montavehículos HIDRÁULICO PISTONES laterales

en tódem, relación 1:1 ó 2:1

PLANTA

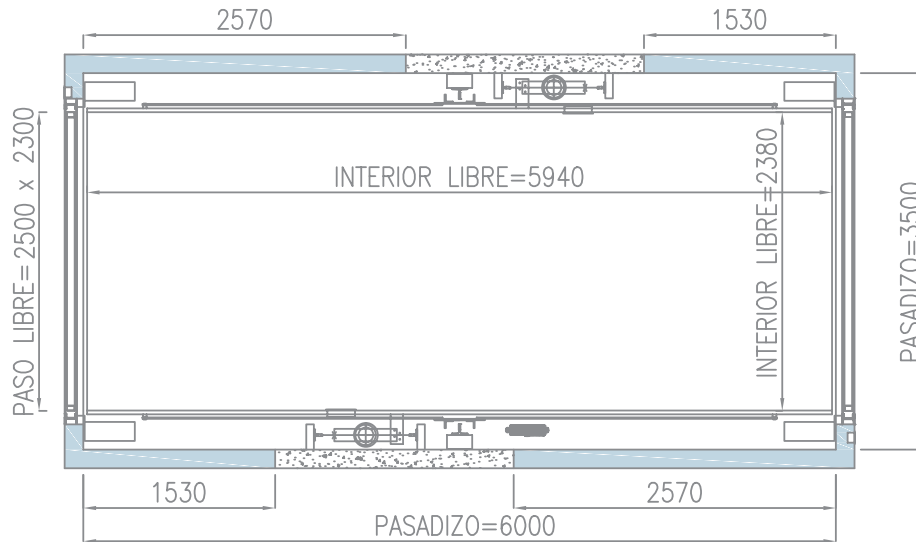

CORTE

